

Molecular Structures of Fulvalenes Derived from Methylidenecycloproparenes: X-ray Structure Determinations and ab Initio Calculations

Yitzhak Apeloig,^{*,†} Roland Boese,^{*,‡} Brian Halton,^{*,§} and Andreas H. Maulitz^{†,‡,||}

Contribution from the Department of Chemistry and the Lise Meitner-Minerva Center for Computational Quantum Chemistry, Technion—Israel Institute of Technology, Haifa 32000, Israel, Institute for Inorganic Chemistry, University of Essen, 45117 Essen, Germany, and School of Chemical and Physical Sciences, Victoria University of Wellington, P.O. Box 600, Wellington, New Zealand

Received August 27, 1997. Revised Manuscript Received August 3, 1998

Abstract: The X-ray crystallographic structures of crystalline fluorenylidene-cycloproparenes **7** and **8** and of dibenzocycloheptatrienyliene **9** are reported. Theoretical studies, using ab initio methods at the HF/6-31G(d,p) and the correlated MP2/6-31G(d,p) levels, have been used to provide assessments of the structure, charge distribution, dipole moment, and thermodynamic stability of the unknown methylidenecyclopropabenzene **3**, the derived parent tria-, penta-, and heptafulvalene derivatives **4–6**, and the crystalline derivatives **7**, **8**, and **9**. The hydrocarbons are found to be polar, and the cycloproparenylidene moiety acts as electron donor in *all but the cyclopropenyliene 4*; this compound is the only fulvalene hydrocarbon in the series calculated to have a negatively polarized cycloproparenyl unit.

Introduction

Strained organic compounds have fascinated chemists for more than a century. Among the most highly strained and intriguing classes of molecules are the *ortho* bridged aromatics whose simplest member is cyclopropabenzene (CPB); **1**.^{1,2} This

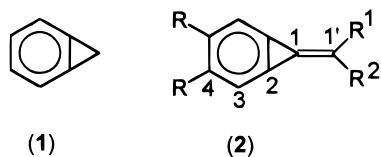

compound and its derivatives continue to find wide appeal among both experimental and theoretical chemists. In many cases, studies have been focused on the strain energy (68 kcal/mol)³ that is imposed by the fusion of a three-membered ring into the benzene nucleus.² Moreover, attention to this class of compounds has been important in the debate over π bond fixation within the six-membered ring,^{4,5} a hypothesis known as the Mills–Nixon effect.⁵

Some 10 years ago, a new class of hydrocarbons based upon the cycloproparene framework was reported⁶ and these compounds, the alkylidenecycloproparenes, e.g., **2**, attracted much interest because they combine into a single molecule two distinct structural features. Thus, methylidenecyclopropabenzene (MCPB; **3**) may be regarded as a benzannulated triafulvene **3a** and an

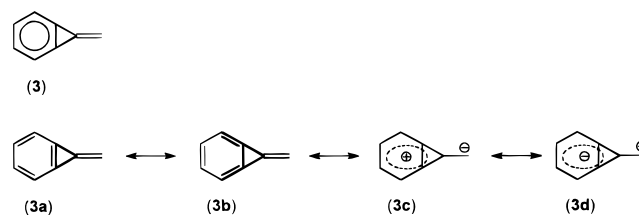

unusual [3]radialene **3b**, all in one.^{6,7} While the synthetic methodology recorded^{6,7} has provided a range of derivatives of **2**, all attempts to synthesize parent **3** have failed thus far.^{7b}

[†] Technion—Israel Institute of Technology.

[‡] University of Essen.

[§] Victoria University.

^{||} Current address: Martin-Luther-Universität Halle-Wittenberg, Kurt-Mothes-Str.2, D-06120 Halle, Germany.

(1) IUPAC name: bicyclo[4.1.0]hepta-1,3,5-triene.

(2) (a) Halton, B. *The Cycloproparenes*. In *The Chemistry of the Cyclopropyl Group*; Rappoport, Z., Ed.; Wiley: Chichester, 1995; Pt. 3, pp 707–772. Halton, B. *Chem. Rev.* **1989**, *89*, 1161. (b) Billups, W. E.; Rodin, W. A.; Haley, M. M. *Tetrahedron* **1988**, *44*, 1305. (c) Müller, P. In *Advances in Theoretically Interesting Molecules*; Thummel, R. P., Ed.; JAI Press: Greenwich, CT, 1995; Vol. 3. Müller, P. In *Carbocyclic Three-Membered Ring Compounds*; Houben-Weyl Methoden der Organischen Chemie; de Meijere, A., Ed.; Thieme: Stuttgart, 1997; Vol. E/17d. (d) Neidlein, R.; Christen, D.; Poignée, V.; Boese, R.; Bläser, D.; Gieren, A.; Pérez, C.; Hübner, T. *Angew. Chem., Int. Ed. Engl.* **1988**, *27*, 294.

(3) Billups, W. E.; Chow, W. Y.; Leavell, K. H.; Lewis, E. S.; Margrave, J. L.; Saas, R. L.; Shieh, J. J.; Werness, P. G.; Wood, J. L. *J. Am. Chem. Soc.* **1973**, *95*, 7878.

(4) (a) Rouhi, A. M. *Chem. Eng. News* **1996**, (April 1), 27. (b) Boese, R.; Bläser, D.; Billups, W. E.; Haley, M. M.; Maulitz, A. H.; Mohler, D. L.; Vollhardt, K. P. C. *Angew. Chem., Int. Ed. Engl.* **1994**, *33*, 313. (c) Bürgi, H.-B.; Baldrige, K. K.; Hardcastle, K.; Frank, N. L.; Gantzel, P.; Siegel, J. S.; Ziller, J. *Angew. Chem., Int. Ed. Engl.* **1995**, *34*, 1454. (d) Siegel, J. S. *Angew. Chem., Int. Ed. Engl.* **1994**, *33*, 1721 and cited. (e) Krygowski, T. M.; Anulewicz, R.; Hiberty, P. C. *J. Org. Chem.* **1996**, *61*, 8533. (f) Anthony, I. J.; Wege, D. *Aust. J. Chem.* **1996**, *49*, 1263. (g) Jemmis, E. D.; Kiran, J. *J. Org. Chem.* **1996**, *61*, 9006. (h) Eckert-Maksić, M.; Glasovc, Z.; Maksić, Z. B.; Zvinski, I. *J. Mol. Struct. (THEOCHEM)* **1996**, *336*, 173. (i) Hiberty, P. C.; Danovich, D.; Shurki, A.; Shaik, S. *J. Am. Chem. Soc.* **1995**, *117*, 7760. (j) Frank, N. L.; Baldrige, K. K.; Gantzel, P.; Siegel, J. S. *Tetrahedron Lett.* **1995**, *36*, 4389. (k) Castro, A.; Martinez, A. *J. Chem. Soc., Perkin Trans. 2* **1994**, 1561. Martinez, A.; Jimeno, M. L.; Elguero, J.; Fruchier, A. *New J. Chem.* **1994**, *18*, 269. (l) Maksić, Z. B.; Eckert-Maksić, M.; Pfeifer, K. H. *J. Mol. Struct.* **1993**, *300*, 445. (m) Hodosecek, M.; Kovacek, D.; Maksić, Z. B. *Theor. Chim. Acta* **1993**, *86*, 343. (n) Eckert-Maksić, M.; Maksić, Z. B.; Hodosecek, M.; Poljanec, K. *J. Mol. Struct. (THEOCHEM)* **1993**, *285*, 187. (o) Koch, W.; Eckert-Maksić, M.; Maksić, Z. B. *Int. J. Quantum Chem.* **1993**, *48*, 319. (p) Koch, W.; Eckert-Maksić, M.; Maksić, Z. B. *J. Chem. Soc., Perkin Trans. 2* **1993**, 2195.

Combining R^1 and R^2 of **2** ($R = H$) into a fully conjugated carbocycle that contains an odd number of carbon atoms results in the fulvalene hydrocarbons **4–6**. Intuitively one expects

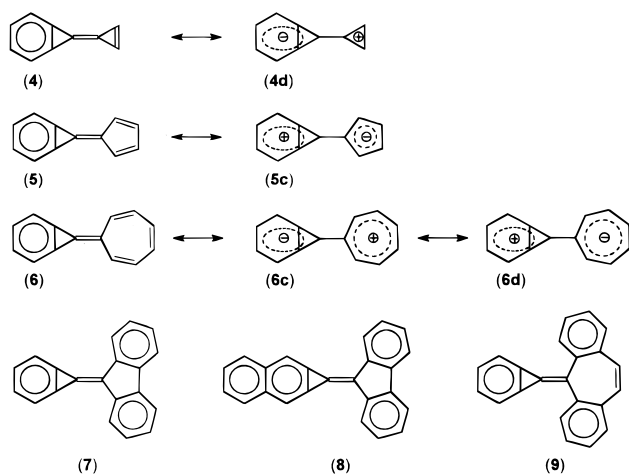

these molecules to exhibit enhanced triafulvene character, cf. **3a**, when the additional ring is able to act as an electron sink; this is typified by the cyclopentadienylidene unit of **5**. Several derivatives of this type have been reported,⁸ and their physical and chemical properties assessed;^{7–9} and low-level HF/STO-3G ab initio calculations of **4–6** were reported by one of us.¹⁰

These calculations showed that there is considerable polarization of the π electron framework as a result of a significant contribution from resonance structures of types **3c** and **3d**. In **3**, **5**, and **6**, the cyclopropabenzene frame is positively charged by a contribution of the type **3c** while in **4** the polarity is reversed; a contribution of the type depicted by **3d**, viz. **4d**, is likely involved. Thus the direction of the dipole in **3** and **5** is computed to be the opposite to that in **4**.¹⁰ The experimentally determined^{8b} dipole moments of the more highly substituted derivatives **7** and **9** (2.6 and 1.2 D, respectively) are in qualitative agreement with the calculated values for **5** and **6**, respectively. Furthermore, it has been shown that the cycloproparenyl skeleton is able to act as an electron acceptor when the substituents of **2** are good electron donors, e.g., $R^1 = R^2 = 4\text{-Me}_2\text{N-C}_6\text{H}_4$, $\mu_{\text{exp}} = 2.2$ D,¹¹ and $\mu_{\text{calc}} = 1.3$ D (the negative end of the dipole is on the cycloproparenyl ring).¹²

Despite interest in the fundamentally important alkylidene-cycloproparenes, the only previously reported crystal structure analyses have involved compounds of type **2** carrying phenyl (**2**; $R = H$; $R^1 = R^2 = \text{Ph}$),^{6b} 4-(dimethylamino)-substituted

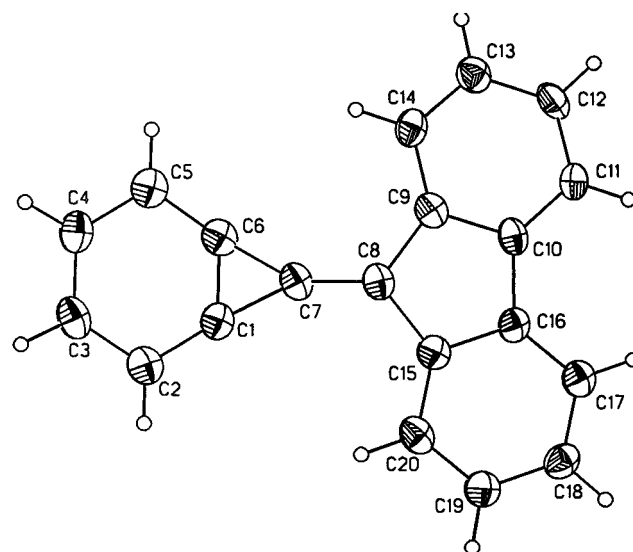

Figure 1. Experimental geometry of **7** shown with thermal ellipsoids (50% probability plots).

phenyl (**2**; $RR = \text{benzo-fused}$; $R^1 = H$ and $R^2 = 4\text{-Me}_2\text{N-C}_6\text{H}_4$),^{11b} and thienyl (**2**; $RR = \text{benzo-fused}$; $R^1 = H$; $R^2 = 2\text{-C}_4\text{H}_5\text{S}$)^{11b} substituents. Moreover, the previous ab initio study devoted to this class of compounds used a minimal basis set (the best calculations that could be carried out at that time)¹⁰ which may lead to erroneous conclusions, especially with regard to charge distribution. Consequently, we have performed a combined experimental–theoretical investigation that provides X-ray crystal structure analyses for the fulvalene derivatives **7–9** and calculations at the ab initio level that provide calculated structures, charge distributions, dipole moments, and the thermodynamic stabilities of each of **3–9** ($R = H$). For comparison we have also calculated several related fulvenes and fulvalenes¹³ in which a cyclopropene ring replaces the cyclopropabenzene ring.

Crystallographic and Computational Methods

The fluorenylidenes **7** and **8** and the cycloheptatrienyldene cycloproparene **9** were prepared according to the procedures previously published by one of us.^{8b} The X-ray crystal structures were determined using a Nicolet R3m/V diffractometer with Mo $K\alpha$ radiation. Relevant data pertaining to the analyses are collected in Table 1 and ellipsoid plots for compounds **7–9** are shown in Figures 1–3, respectively. Important bond lengths are provided in Table 2, and detailed information with tables of positional and thermal parameters are available as Supporting Information.

Quantum mechanical calculations were carried out by both the semiempirical PM3 and ab initio methods using the GAUSSIAN 92¹⁴ and SPARTAN 3.1¹⁵ programs. The structures of the unknown methylenecycloproparenes **3–6** and those of the known derivatives **7–9** were fully optimized. For the ab initio HF calculations, the STO-3G and 6-31G(d,p) basis sets were used. The geometries of **3–6** were

(13) Scott, A. P.; Agrat, I.; Biedermann, P. U.; Riggs, N. V.; Radom L. *J. Org. Chem.* **1997**, *62*, 2062. These authors reported the optimized structures of several simple fulvenes (**10**, **16**, **17**) and fulvalenes (**11**, **13**, **20**), used as reference molecules in our paper. This paper was published after our study had been completed and it does not discuss fulvalenes derived from methylenecycloproparene.

(14) GAUSSIAN 92, revision C: Frisch, M. J.; Trucks, G. W.; Head-Gordon, M.; Gill, P. M. W.; Wong, M. W.; Foresman, J. B.; Johnson, B. G.; Schlegel, H. B.; Robb, M. A.; Replogle, E. S.; Gomberts, R.; Andres, J. L.; Raghavachari, K.; Binkley, J. S.; Gonzales, C.; Martin, R. L.; Fox, D. J.; Defrees, D. J.; Baker, J.; Stewart, J. J. P.; Pople, J. A. Gaussian: Pittsburgh PA, 1992.

(15) SPARTAN version 3.1. Wavefunction, Inc. 18401 Von Karman Ave., #370, Irvine, CA 92715, 1994.

(5) Mills, W. H.; Nixon, I. G. *J. Chem. Soc.* **1930**, 2510.

(6) (a) Halton, B.; Randall, C. J.; Stang, P. J. *J. Am. Chem. Soc.* **1984**, *106*, 6108. (b) Halton, B.; Randall, C. J.; Gainsford, G. J.; Stang, P. J. *J. Am. Chem. Soc.* **1986**, *108*, 5949.

(7) (a) Halton, B.; Stang, P. J. *Acc. Chem. Res.* **1987**, *20*, 443. (b) Halton, B.; Stang, P. J. *Synlett* **1997**, 145.

(8) (a) Halton, B.; Buckland, S. J.; Mei, Q.; Stang, P. J. *Tetrahedron Lett.* **1986**, *27*, 5159. (b) Halton, B.; Buckland, S. J.; Lu, Q.; Mei, Q.; Stang, P. J. *J. Org. Chem.* **1988**, *53*, 2418.

(9) Halton, B. *Pure Appl. Chem.* **1990**, *62*, 541.

(10) (a) Apeloig, Y.; Arad, D. *J. Am. Chem. Soc.* **1986**, *108*, 3241. (b) Apeloig, Y.; Karni, M.; Arad, D. In *Strain and its Implications in Organic Chemistry*; de Meijere, A., Blechert, S., Eds.; Kluwer: Dordrecht, 1989; p 457. See also citation 13 in ref 8b.

(11) (a) Halton, B.; Lu, Q.; Stang, P. J. *J. Chem. Soc., Chem. Commun.* **1988**, 879. Halton, B.; Lu, Q.; Melhuish, W. H. *J. Photochem Photobiol., A: Chem.* **1990**, *52*, 205. (b) Halton, B.; Cooney, M. J.; Davey, T. W.; Forman, G. S.; Lu, Q.; Boese, R.; Bläser, D.; Maulitz, A. H. *J. Chem. Soc., Perkin Trans. 1* **1995**, 2819.

(12) The geometry of **2** with $R^1 = R^2 = 4\text{-Me}_2\text{N-C}_6\text{H}_4$ (C_2 symmetry) was optimized at the HF/6-31G(d) level of theory; Maulitz, A. H., unpublished results.

Table 1. Experimental Data from X-ray Structure Analyses of Compounds 7–9

	7	8	9
chem formula	C ₂₀ H ₁₂	C ₂₄ H ₁₄	C ₂₂ H ₁₄
cryst size (mm ³)	0.28 × 0.26 × 0.11	0.38 × 0.21 × 0.18	0.36 × 0.33 × 0.21
temp (K)	125	110	116
space group	C2/c	P2 ₁ 2 ₁ 2 ₁	P2 ₁ /c
Z	8	4	8
a (Å)	31.825(8)	15.525(2)	7.661(1)
b (Å)	5.642(2)	15.523(2)	18.354(3)
c (Å)	14.678(4)	6.347(1)	21.039(4)
α (deg)	90	90	90
β (deg)	94.20(2)	90	90.19(1)
γ (deg)	90	90	90
V (Å ³)	2628(1)	1529.6(3)	2958.0(7)
d _{calc} (g cm ⁻³)	1.275	1.313	1.250
μ (mm ⁻¹)	0.07	0.07	0.07
2θ range (deg)	3 ≤ 2θ ≤ 45	3 ≤ 2θ ≤ 45	3 ≤ 2θ ≤ 55
total no. of unique reflctns	1667	2344	6777
total no. of obsd reflctns F _o ≥ 4σ(F)	1182	2104	5098
R, R _w	0.059, 0.062	0.0313, 0.0353	0.044, 0.053

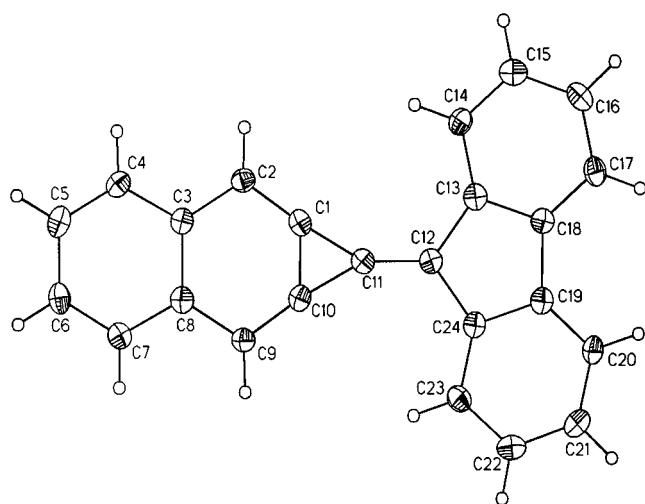
**Figure 2.** Experimental geometry of **8** shown with thermal ellipsoids (50% probability plots).

also optimized at the MP2(fc)/6-31G(d,p) level (using the frozen core approximation) in order to assess the influence of electron correlation. All calculated geometries were fully optimized and characterized at the HF/6-31G(d,p) level by their Hessian matrix to be minimums on the potential energy surface. For convenience, the labeling scheme for bond distances and angles used throughout the paper is depicted in Figure 4.

Results and Discussion

(a) Dipole Moments and Charges. To gain insight into the charge distribution of molecules **3–9**, we have used the

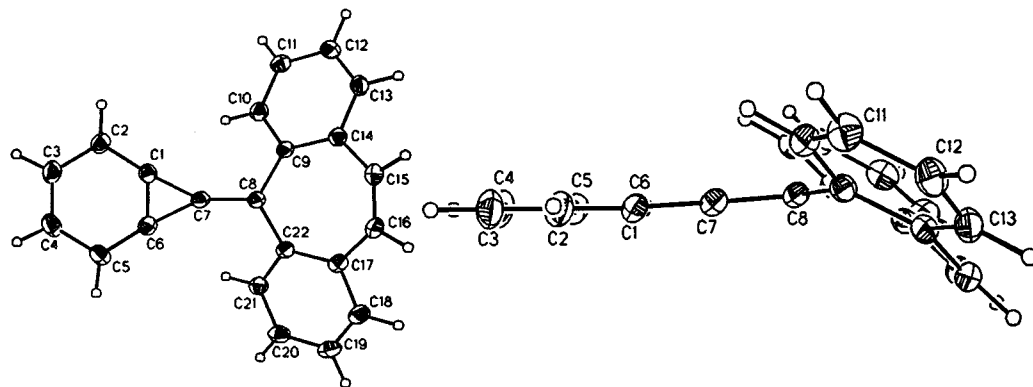
**Figure 3.** Experimental geometry of **9** shown with thermal ellipsoids (50% probability plots) from top and side.

Mulliken population method to calculate both the π charges and the total charges of these molecules at the HF/6-31G(d,p) level of theory. The calculated π Mulliken charges on the cyclopropabenzene fragment are listed in Table 3. The total charges are given as Supporting Information in Table S1.

The calculated π charges are the most relevant to a discussion of the possible contributions of polar resonance structures such as **3c**, **3d**, **4d**, etc. to the electronic structure of **3–9**. In **3**, C1' is negatively charged in the π system (i.e., by 0.14 e; Table 3) indicating a significant contribution of resonance structure **3c**. The π charge on the CPB skeleton is positive and 0.25 e. This polarization is significantly smaller than in methylidencyclopropene **10**, where the exocyclic methylene carbon C1' carries

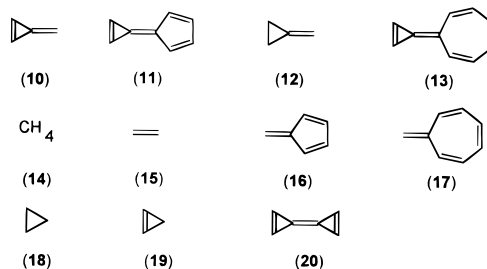

a negative π charge of 0.24 e and the cyclopropene fragment carries a positive charge of 0.32 e (Table 3). Thus, the CPB skeleton is less efficient in supporting a positive charge than the cyclopropene ring, and this suggests that resonance structure **3c** contributes less than the analogous polar structure of **10**. In all other molecules except **4**, the CPB fragment also carries a

Table 2. Calculated and Experimental Bond Lengths (Å) and Calculated Energies (au) for **1** and the Alkylidenecyclopropenes **3–9**^a

compd	method	<i>r</i> ₁	<i>r</i> ₂	<i>r</i> ₃	<i>r</i> ₄	<i>r</i> ₅	<i>r</i> ₆	<i>r</i> ₇	<i>r</i> ₈	<i>r</i> ₉	<i>r</i> ₁₀	energy
1	HF/6-31G(d,p)		1.494	1.332	1.370	1.400	1.394					-269.400 995
	X-ray ^{1d}		1.498(3)	1.33(4)	1.363(3)	1.387(4)	1.390(5)					
3	HF/6-31G(d,p)	1.318	1.435	1.347	1.382	1.388	1.407					-306.319 540
4	HF/6-31G(d,p)	1.309	1.443	1.363	1.363	1.411	1.384	1.431	1.301			-381.944 927
5	HF/6-31G(d,p)	1.337	1.421	1.346	1.388	1.382	1.415	1.460	1.342	1.465		-458.942 495
6	HF/6-31G(d,p)	1.336	1.429	1.354	1.377	1.394	1.401	1.467	1.332	1.464	1.330	-535.832 066
	X-ray	1.331	1.425	1.347	1.384	1.386	1.410	1.472	1.401	1.472		
7	HF/6-31G(d,p)	1.331	1.425	1.347	1.384	1.386	1.410	1.472	1.401	1.472		-764.287 064
	X-ray	1.338(5)	1.441(4)	1.377(5)	1.385(4)	1.393(7)	1.410(6)	1.470(7)	1.407(7)	1.469(5)		
8	HF/6-31G(d,p)	1.329	1.427	1.374	1.353	1.426	1.431	1.474	1.400	1.474		-916.941 255
	X-ray	1.346(2)	1.430(2)	1.390(2)	1.362(2)	1.423(2)	1.451(2)	1.465(2)	1.412(2)	1.474(2)		
9 ^b	HF/6-31G(d,p)	1.345	1.431	1.341	1.382	1.389	1.406	1.519	1.410	1.464	1.320	-841.166 658
	X-ray	1.347(2)	1.438(2)	1.371(2)	1.382(2)	1.399(2)	1.406(3)	1.487(1)	1.414(1)	1.462(2)	1.341(2)	

^a The designation of the bonds is shown in Figure 4. All molecules were calculated with *C*_{2v} symmetry. ^b *C*_s symmetry.

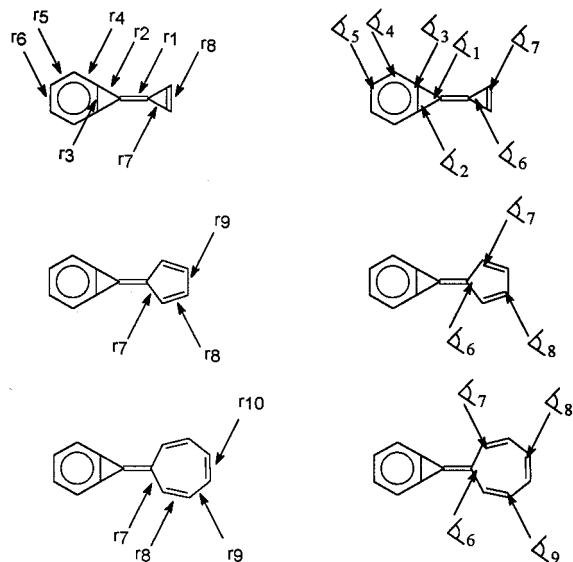
**Figure 4.** Labeling scheme for the geometrical parameters of molecules **1–9** used in Tables 2 and 3 and in the text.**Table 3.** Calculated Mulliken π Charges at HF/6-31G(d,p)^a

	C1'	C1	C2	C3	C4	π_{CPB}^b	π^c	Σ_{CPB}^d
3	1.14	0.95	0.93	0.99	98	0.25	-0.14	0.16
4	0.98	1.17	0.93	1.03	100	-0.09	0.22	-0.06
5	1.08	0.91	0.91	0.99	96	0.37	-0.22	0.32
6	1.06	1.01	0.92	1.01	98	0.17	0.02	0.06
7	1.10	0.94	0.92	0.99	97	0.30	-0.02	0.19
8	1.04	0.97	0.94	1.01	96	0.21	0.08	0.08
9 ^b	1.10	0.98	0.92	1.00	97	0.24	0.04	0.15
10	1.24	0.91	0.89			0.32	-0.24	0.23
11	1.15	0.85	0.86			0.44	-0.30	0.29
12	1.03	0.95				0.05	-0.03	0.08
13	1.15	0.94	0.88			0.30	-0.14	0.16

^a For atom numbering, see 2. ^b Excess π charge on the CPB fragment in **3–9** and the three-membered ring in **10–13**. ^c Excess π charge on the ring system connected to C1'. ^d The sum of the total charges in the cyclopropabenzene fragment.

positive π charge that ranges from +0.17 in **6** to +0.37 in **5** (Table 3). This indicates that resonance structures of type **3c**, i.e., **5c**, **6c**, etc., are significant for these compounds and especially for **5** which exhibits the strongest π polarization among **3–9**. However, we note that in the parent **11** calicene of this type the polarization is even higher (Table 3). Among all the molecules studied, it is only in **4** that the cyclopropabenzene ring carries a negative π charge (although small, -0.09 e), and the cyclopropene skeleton carries a very significant positive charge (0.22e), indicating the importance of resonance structure **4d**.

Table 4. Calculated (HF/6-31G(d,p)) and Experimental Dipole Moments with *C*_{2v} Symmetry unless Otherwise Stated

	direction of μ_{calc}^a	$ \mu _{\text{calc}}/\text{HF/6-31G(d,p)}$
1		0.1
3	→	1.8
4	←	2.6
5	→	4.3
6	→	1.7
7	→	3.5 (2.6) ^b
8	→	2.3
9	→	2.7; 2.1 (<i>C</i> _s) (1.2) ^b

^a An arrow pointing to the right indicates that the positive end of the dipole is on the cyclopropene ring. ^b Experimental value.⁸

The C1=C1' π bond is usually highly polar, with a π charge difference between C1 and C1' of as much as 0.19 e in **3** and **4**, and 0.17 and 0.16 e in **5** and **7**, respectively. In **6**, **8**, and **9**, this polarization is lower and in the range of 0.07–0.12 e. We note that except in **4** C1' is negatively charged. This implies that electrophilic addition is expected to occur at C1' of the C1=C1' bond in accord with the reported¹⁶ chemical behavior of 1-(diphenylmethylidene)-1*H*-cyclopropabenzene (**2**; R = H; R¹ = R² = Ph) with electrophiles. In contrast, in (unknown) **4** electrophilic attack is directed by the negative charge to C1.

The trends in the total charges and in the π charges parallel in general each other, and either of them can be used to gain information about the principle electronic structure of the molecules. In all molecules, C1' carries a partial negative total charge, whereas the charge at C1 (except for **6**) is slightly positive. In **4** and **6**, the C1=C1' bond is only slightly polar with a charge difference between C1 and C1' of 0.09 and 0.07 e, respectively. The sum of the calculated Mulliken total charges on the entire CPB skeleton, given in Table 3 as Σ_{CPB} , indicates that the cyclopropabenzene fragment is positively charged in all molecules *except for 4*, where the charge is slightly negative. Thus it is only the electron donor ability of the cyclopropenylidene moiety (as in **4**) that is sufficiently high, to "force" the fused CPB ring system to be slightly negatively charged. The strongest polarization is observed for **5** where the CPB skeleton carries a total charge of +0.32 e.

The calculated total charge distribution is reflected in the direction of the calculated dipole moments of **3–9**. The calculated HF/6-31G(d,p) values are given in Table 4. For **7** and **9**, for which experimental values are also available, the agreement with the calculations is reasonable for **7** and poor (see below) for **9** (Table 4). It is known that CI methods are needed for calculating reliable dipole moments,¹⁷ but these

(16) Buckland, S. J.; Halton, B.; Mei, Q.; Stang, P. J. *Aust. J. Chem.* **1987**, *40*, 1357.

(17) Replogle, E. S.; Trucks, G. W.; Staley, S. W. *J. Phys. Chem.* **1991**, *95*, 6908.

methods are still too time-consuming for the relatively large molecules investigated in the present study.

Parent **3** has a relatively small dipole moment of 1.8 D with the positive pole at the CPB ring, as expected from resonance structure **3c**. Both benzocalicene **5** and its derivative **7** have higher polarities and thus higher dipole moments than **3**. This is easily explained in terms of the Hückel rule and the higher contributions of polar resonance structures such as **5c** and **7c** that have a cyclopentadienyl anion unit linked to the positively charged cyclopropabenzene fragment. The predicted dipole moments of **5** and **7**, 4.3 and 3.5 D, respectively, are high and they parallel the high polarization of the π electrons in these molecules (Table 5). The benzotriafulvalene **4** also has a relatively high dipole moment of 2.6 D, but this lies in the direction opposite to all the other molecules. This is consistent with the nonfused cyclopropene ring repelling an electron more strongly than the CPB skeleton which is "forced" to accept significant negative charge as depicted by resonance structure **4d**. The heptafulvalene **6** has a relatively small dipole moment, similar to that of **3** and pointing in the same direction, in agreement with the π charge distribution discussed above. Thus, qualitative considerations, which may suggest that in **6** the "aromatic" resonance structure **6d** contributes significantly (as in **4**), are misleading.

(b) Geometry. The HF/6-31G(d,p) calculated (and experimental where available) bond lengths of **1** and **3–9** are given in Table 2. The calculated bond lengths at PM3, STO-3G, and for some of the molecules also at MP2/6-31G(d,p) are given in Table S3 of the Supporting Information. The calculated bond angles (and experimental where available) are given in Table S4. The corresponding labeling scheme is given in Figure 4. The discussion for the parent compounds is based on the MP2/6-31G(d,p) values.

Comparison of the calculated structure of **3** (the experimental geometry is not yet known) with that of **1** (Table 2) shows that the incorporation of an exocyclic double bond at C1 of cyclopropabenzene **1** has marked effect on the geometry of the cyclopropabenzene skeleton. The bridge bond (r_3) of **3** is lengthened by 0.015 Å at HF/6-31G(d,p) (0.028 Å MP2/6-31G(d,p)) while the vicinal three-membered ring σ bonds (r_2) are shortened by 0.059 Å (0.060 Å at MP2/6-31G(d,p)). Similar changes are observed when the same bond lengths of cyclopropane or cyclopropene are compared with those in the corresponding methylene derivatives. In these molecules, methylene fusion causes a lengthening of the basal (anti) bonds of cyclopropane and of cyclopropene by 0.035 and 0.026 Å, respectively, and a shortening of the vicinal bond by 0.037 and 0.060 Å, respectively (all values at MP2/6-31G(d,p)). Comparable changes in r_2 and r_3 occur for derivatives of **1** in which C1 carries highly electronegative substituents, e.g., 1,1'-difluorocyclopropabenzene,² where calculated r_2 and r_3 are 1.458 and 1.372 Å,¹⁸ respectively (the experimental values are 1.448(1) and 1.360(1) Å, respectively¹⁹).

Aromatic " π bond fixation",⁴ known as the Mills–Nixon effect,⁵ has often been discussed in papers concerning the cycloproparenes, but our calculations provide no evidence for its presence in **3**. This is not too surprising because neither the experimental^{2d} nor the calculated²⁰ geometry of **1**, nor even the calculated geometry of tricyclopropabenzene²¹ shows any significant bond localization.²²

The length of the exocyclic double bond that connects the two rings in the cross-conjugated systems (r_1) is of particular interest. Thus, r_1 in **3** (1.337 Å) is slightly longer than in methylenecyclopropane **12** (1.326 Å) and in methylenecyclopropene **10** (1.331 Å), and this is consistent with some contribution from resonance structure **3c**. The calculated r_1 distances at MP2/6-31G(d,p) (Table S3, Supporting Information) are 1.337 (**3**), 1.325 (**4**), 1.356 (**5**), and 1.365 Å (**6**). These values show that r_1 cannot be interpreted solely in terms of contributions of polar resonance structures, e.g., structures **4d** and **5c** (the major contributing structures to **4** and **5**, respectively; see above), because both suggest elongation of r_1 relative to **3** and this is in contrast to the computational results. In the analogous three-membered-ring derivatives **10–13**, r_1 changes more regularly, qualitatively consistent with control of r_1 by polar resonance contributions (e.g., **12**, 1.308 Å; **10**, 1.342 Å; **11**, 1.324 Å; and **13**, 1.335 Å). The fact that r_1 varies by only ~ 0.01 Å among compounds **5–9** (Table 2) indicates that this bond is insensitive to changes in the charge distribution in these molecules, cf. **5** and **6** (Table 3 and Table S1, Supporting Information). In fact, the calculated¹⁰ dipole moment of **6** has the seven-membered ring at the negative pole (Table 4).

The only cases for which there is a direct experimental–theoretical comparison are **7–9** (Table 2) for which the HF/6-31G(d,p) calculated values are in good agreement with experiment. For molecules **1–6**, where we have both MP2/6-31G(d,p) and HF/6-31G(d,p) calculations, we find that the MP2-optimized bond lengths are generally longer by 0.01–0.02 Å than both the HF and the experimental bond lengths. Thus, the discussion for the substituted systems is based on the HF/6-31G(d,p) calculated values given in Table 2.

An examination of the experimental and calculated bond length distances within the cyclopropabenzene fragment (r_2 – r_6 ; Table 2) reveals that the CPB skeletons of **3**, **5**, **6**, and **7** are very similar and the theoretical–experimental agreement is good (Table 2). The unknown **4** is exceptional and shows extreme values for r_4 – r_6 . This is probably connected with the fact that only in **4** is the CPB ring negatively charged.

Optimization of the C_{2v} structure of **9** at HF/6-31G(d,p) imposing only C_s symmetry results in a distortion toward a boat conformation that is very similar to the experimental structure shown in Figure 3. The planar C_{2v} structure of **9** is a transition state for the isomerization of two identical C_s structures, and it lies 16 kcal/mol (HF/6-31G(d,p)) higher in energy than these. We attribute the boat conformation of **9** to strong steric repulsions in the planar geometry of **9** between the cyclopropene ring and the ortho hydrogen atoms of the benzene rings fused to the cycloheptatrienyliene moiety. These interactions are not present in **6**, and therefore, it remains planar even when the C_{2v} symmetry restrictions are lifted, although as pointed out above, cross-conjugation between the two fragments is weak (see above). Electronic effects may also contribute to the distortion of **9**, from planarity. In the planar geometry of **6** and **9** conjugation between the two sides of the molecules is possible and the seven-membered ring is slightly negatively charged as expressed in **6c** (see above); thus delocalization leads to an antiaromatic 8π electron system. Distortions from planarity reduce the antiaromatic character of the seven-

(21) (a) Boese, R.; Maulitz, A. H., unpublished results. MP2(fu)/6-31G(d). D_{3h} -tricyclopropabenzene has $r_3 = 1.377$ Å and $r_4 = 1.367$ Å, respectively. (b) Baldrige, K. K.; Siegel, J. S. *J. Am. Chem. Soc.* **1992**, *114*, 9583. (c) Stanger, A. *J. Am. Chem. Soc.* **1991**, *113*, 8277. (d) Dewar, M. J. S.; Holloway, M. K. *J. Chem. Soc., Chem. Commun.* **1984**, 1188.

(22) For evidence that bond fixation occurs in other systems, see: Frank, N. L.; Siegel, J. S. *Advances in Theoretically Interesting Molecules*; JAI Press Inc.: Greenwich, CT, 1995; Vol. 3, pp 209–260.

(18) MP2(fc)/6-31G(d); Maulitz, A. H., unpublished results.

(19) Boese, R. In *Advances in Strain in Organic Chemistry*; Halton, B., Ed.; JAI Press: London, 1992; Vol. 2, p 212.

(20) Baldrige, K. K.; Siegel, J. S. *J. Am. Chem. Soc.* **1992**, *114*, 9583.

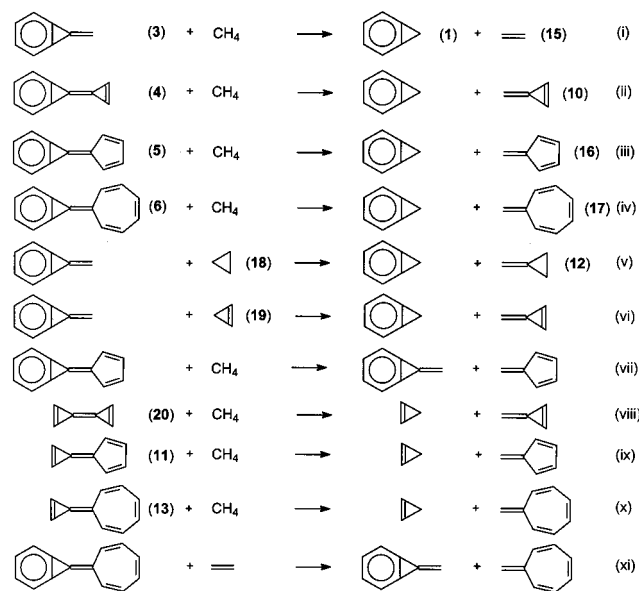
Scheme 1. Calculated Isodesmic Equations

membered ring, thus stabilizing the molecule. While Daub²³ has pointed out previously that electron-rich heptafulvenes prefer bond localization which is accompanied by nonplanarity, Radom and colleagues¹³ have recently shown that the cycloheptatrienyliene moiety is distorted from planarity if hydrogen contacts become too close in a cross-conjugated ring system such as in pentaheptafulvalene or heptafulvalene.

(c) Thermodynamic Properties. To learn about the thermodynamic stabilities of the methylidenecycloproparene fulvalenes, we have calculated the bond separation energies given in eqs i–xi shown in Scheme 1. The calculated total energies and the zero point energies (ZPE) of all the molecules in eqs i–xi are given in Table S5 of the Supporting Information, and the calculated reaction energies are given in Table 5.

Table 5. Calculated Energies of Eqs i–xi at MP2/6-31G(d,p) and MP2/6-31G(d,p) + ZPE(HF/6-31G(d,p))

eq	ΔE_{rel}	eq	ΔE_{rel}
i	+9.3	vii	+8.3
ii	+4.9	viii	+13.0
iii	+17.6	ix	+15.1
iv	+15.0	x	+6.4
v	+10.9	xi	+5.7
vi	+2.7		

The calculated reaction energies of eqs i–iv are all positive and are +9.3, +4.9, +17.6 and +15.0 kcal/mol, respectively (Table 5). The positive energies indicate that the fulvalenes **4–6** and methylidenecyclopropabenzene **3** are all *stabilized* relative to the separated cyclopropabenzene (**1**) and the corresponding fulvenes (ethene in the case of eq. i). Apparently, electronic stabilization resulting in part from conjugation and ionic resonance structures such as **3c**, **3d**, **5c**, etc., is substantially larger than the additional strain resulting from fusion of the two ring systems. The fact that the C–H bond in methane is stronger than in ethene or in cyclopropane also contributes to the relatively high energy of eq. i. The conclusion that MCPB (**3**) is stabilized by the exocyclic double bond relative to CPB (**1**) is also evident from the calculated energy difference of +10.9 kcal/mol for eq. v, which compares the energy of **3** with that of methylidenecyclopropane (**12**). Reaction vi, which is

endothermic by 2.7 kcal/mol, indicates the slightly higher stability of **3** compared with methylidenecyclopropane (**10**). The stabilization of the calicene derivative **5** (eq. iii) or the cycloheptatrienyliene derivative **6** (eq. iv) compared to the separated rings is significantly larger than that of methylidenecyclopropabenzene (**3**). Note that the difference in the energies of eq. i and eq. iii is equivalent to the energy of eq. vii (i.e., the calculated energy of reaction vii is 17.6 – 9.3 = 8.3 kcal/mol) and the same is valid for the other comparisons made with eq. i. The significant stabilization of **6** relative to **3** (i.e., 5.7 kcal/mol, eq. xi) is especially surprising in view of its very small charge polarization (see above and Table 3). The conclusion from this is that dipolar resonance structures such as **6c** or **6d** are not important in determining the thermodynamic stability of **6**. Apparently, other factors contribute to the unexpected high endothermicity of eqs. iv and xi. In contrast, **4** (eq. ii) is less stabilized than **3** (eq. i) by the exocyclic fragment, probably indicating the reluctance of the cyclopropabenzene moiety to accommodate negative charge (Table 3) as requested by structure **4d**, which is imposed by the strong preference of the cyclopropene ring to carry a positive charge (see above).

Comparison of the “fulvalenecycloproparenes” **4–6** with the corresponding nonbenzofused analogues **20**, **11**, and **13**, respectively, is also of interest (i.e., comparison of eqs. ii, iii, and iv with equations viii, ix, and x, respectively). Thus the energies of eqs. iii and ix are similar, viz. 17.6 and 15.1 kcal/mol, respectively, showing that when the second ring is a cyclopentadienyl ring the fulvalene skeleton is stabilized to a similar degree irrespective of whether it is fused to a cycloproparene or a cyclopropene moiety. The situation is different when the second ring is a cyclopropene or cycloheptatrienyl ring as shown by eqs. viii and x. In the case of a cyclopropene ring, stabilization is significantly stronger when conjugation is to a second cyclopropene ring as in **20** (stabilization of 13 kcal/mol, eq. viii) than when conjugated to a cycloproparene skeleton as in **4** (stabilization of 4.9 kcal/mol, eq. ii). The opposite behavior is found for the cycloheptatrienylenes, which are best stabilized when conjugated to a cycloproparene as in **6** (stabilization of 15.0 kcal/mol, eq. iv) than to a cyclopropene ring as in **13** (stabilization of 6.4 kcal/mol, eq. x).

Conclusions

Ab initio calculations of **3–9** and X-ray crystal structure investigations of **7–9** show that these cross-conjugated systems have planar structures, except for the dibenzotriaheptafulvalene **9** where the seven-membered ring is puckered. The calculated dipole moments show that in all the “fulvalenecycloproparenes” the cyclopropabenzene skeleton is positively charged; only in benzotrifulvalene **4** is the cyclopropabenzene skeleton negatively charged. Methylidenecycloproparene **3** and the corresponding benzofulvalenes **4–6** are all thermodynamically stabilized with respect to cyclopropabenzene and the corresponding fulvene (ethene in case of **3**). The largest stabilization energies are calculated for **5** and **6**, while **4** is thermodynamically less stable than **3**.

The structural changes in **3** compared to **1** can be described in terms of contributions from resonance structure **3c** in which the exocyclic methylene group behaves as an electron-attracting substituent and carries a negative charge. This charge distribution is in line with the reported chemical behavior of 1-(diphenylmethylene)-1*H*-cyclopropabenzene (**2**; R = H; R¹ = R² = Ph) with electrophiles.

Acknowledgment. Dedicated to the memory of Professor Saul Patai (Hebrew University of Jerusalem), a distinguished

(23) Daub, J. *Chimia* **1987**, *41*, 52.

teacher and editor. The work at the Technion was supported by the German Federal Ministry of Science, Research, Technology and Education (BMBF), the Minerva Foundation, and the Fund for the Promotion of Research. In Essen, support was provided from the Deutsche Forschungsgemeinschaft and the Fonds der Chemischen Industrie. Continuous financial support in New Zealand from the VUW Internal Grants Committee and a visiting professorship at the Max Planck Institute for Polymer Research, Mainz (to B.H.) has greatly assisted this collaboration. We gratefully acknowledge general support and generous computational time (to A.H.M.) at the Hochschulrechenzentrum Essen/Germany, the Regionales Rechenzentrum Köln/Germany, and the National Center of Supercomputing Applications (NCSA) at Champaign/Urbana, IL.

Note Added in Proof. Structural data and computational studies on dyes derived from **2** (e.g., RR = benzo; R¹R² = xanthenylidene) have now appeared: Halton, B.; Cooney, M. J.; Boese, R.; Maulitz, A. H. *J. Org. Chem.* **1998**, *63*, 1583.

Supporting Information Available: Additional computational results at various levels of theory of molecular geometries, total charges, dipole moments and total energies (5 tables). A complete listing of details of the structure determinations, atomic coordinates, bond distances, and bond angles (25 pages, print/PDF). Ordering information is given on any current masthead page. See any current masthead page for ordering information and Web access instructions.

JA973020I